



# 6x3 Vac Assist Diesel-Driven Centrifugal Pump Trailer Package 100-1063

## Pump Specifications

Make	Pioneer
Model	PP63C17
Size	6" x 3" (150 mm x 76 mm)
Impeller Diameter	17" (432 mm)
Impeller Type	Enclosed
Max Flow	1,090 gpm (248 m <sup>3</sup> /h)
Max Head	460 feet (140 meters)
Max. Operating Speed	2,400 rpm
Max. Operating Temp.	200 °F (93 °C)
Max. Operating Press.	260 psi (1,800 kPa)
Maximum Solid Size	0.75 inch (19 mm)

## Engine Specifications

FT4 Engine Type	John Deere 4045HFC06
Displacement	275 cu. in. (4.5 l)
Fuel Consumption	7.03 gph (26.6 l/h) @ 1,800 rpm
Continuous HP	142 hp (106 kW)
Peak Intermittent HP Rating	173 hp (126 kW)
FT4 Specifics (Def or No Def, DOC, SCR, etc.)	DOC
Safety Shut-Down Switches	Low oil pressure, high temp., v-belt failure
Instrument Panel	Oil pressure & temp gauge, ampmeter, hourmeter, tachometer

## Priming System

Priming System	Mechanically driven diaphragm-style vacuum pump
Air Removal Cap.	50 cfm (.02 cms)
Priming Chamber	Positive sealing air separation w/stainless steel components
Discharge Check Valve	Swing style; ductile iron w/nitrile disc Oil-lubricated mech seal allows pump to run completely dry without damage



## Features & Benefits

- Indefinite run-dry capability
- Extreme flow technology
- Environmentally safe priming system
- Auto-start controls
- Skid options available

## Package Specifications

Fuel Capacity	135 U.S. gallons
Control Panel	Controls Inc CX - Programmable Panel
Operating Speed (Min/Max)	1,200 / 2,400 rpm
Weight (Dry/Wet)	5,690 / 6,649 lbs
Instrument Compatibility	High/low level floats, transducers
Trailer Brakes	Electric
Optional Adders	NTE automation

## Materials of Construction

Impeller	CA6NM Stainless Steel
Shaft	17-4 PH Stainless Steel
Wear Ring	ASTM A48 Class 40 Gray Iron
Suction Cover	Ductile Iron ASTM A536 65-45-12
Volute	Ductile Iron ASTM A536 65-45-12
Brac-Plate/Bracket	Ductile Iron ASTM A536 65-45-12
Mechanical Seal	Silicon Carbide rotating and Tungsten Carbide stationary



# 6x3 Vac Assist Diesel-Driven Centrifugal Pump Trailer Package 100-1063

## Mechanical Dimensions

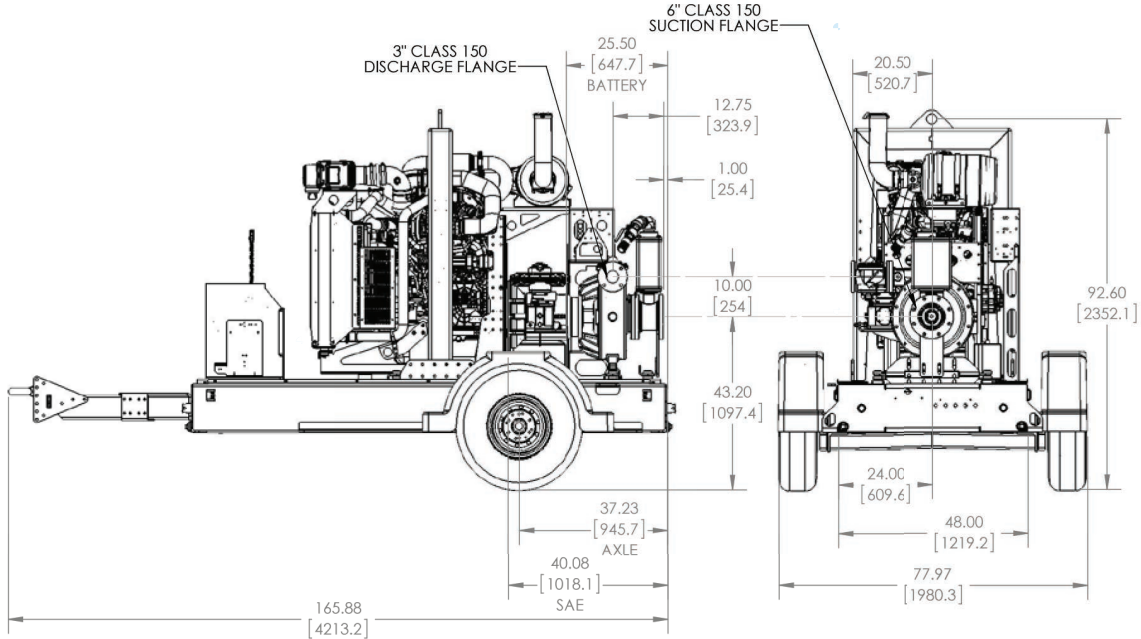

## Performance Curve

